

WORKSHOP RECOMMENDATIONS



WELDING RECOMMENDATIONS

SSAB's protection plates have a lean chemical composition which supports a high degree of weldability. Furthermore, these steel grades can be welded by any conventional welding method. Suitable types of consumables cover ferritic and stainless types where the recommended ones depend on the steel grade. All ArmoX® grades can be welded to other weldable steels.

EDGE PREPARATION

A good fit between the work pieces is essential to minimize stresses and thereby the risk of cracking. All types of impurities on and near the edges, such as mill scale, rust, oil, paint, moisture etc. must be removed before welding.

DEFINITION OF HEAT INPUT

Welding with recommended heat input results in good mechanical properties in the joint. The heat input (Q), see equation 1, from a welding performance depends of the current, voltage and travel speed and describes the delivered energy/length to the joint and affects the mechanical properties of the welded joint. Its' value affects the mechanical properties of the welded joint. During welding there is a loss of energy in the arc. The thermal efficiency factor [k] expresses the part of the heat input that is transferred to the joint. Different methods of welding have varying thermal efficiency, see Table 1 for approximate values of this property.

$$Q = \frac{k \times U \times I \times 60}{v \times 1000}$$

Q = Heat input [kJ/mm] v = Welding speed [mm/min]
 U = Voltage [V] k = Thermal efficiency
 I = Current [A] [dimensionless]

Equation 1 Heat input calculation

TACK WELDING

During tack welding each tack weld should be at least 50 mm in length to avoid hydrogen cracks in the joint.

CARBON EQUIVALENTS FOR ARMOX®

The resistance to hydrogen cracking for a steel can be expressed by its carbon equivalent. There are different types of carbon equivalents where of equivalents according to CET and CEV are the most internationally common ones. Low values of the carbon equivalents mean less need of preheat during welding. Typical values for ArmoX® are given in Table 1.

Steel grade	Thickness range	CET ¹ [%]	CEV ¹ [%]
ArmoX® 370T Class 1	3–100 mm	0.46–0.50	0.67–0.73
ArmoX® 370T Class 2	3–152 mm	0.46–0.53	0.67–0.93
ArmoX® 440T	4–80 mm	0.38–0.41	0.67–0.71
ArmoX® 500T	3–130 mm	0.46–0.53	0.67–0.93
ArmoX® 520T	4–12 mm	0.46	0.67
ArmoX® 560T	4–15 mm	0.46	0.62
ArmoX® 600T	4–20 mm	0.53–0.58	0.66–0.82
ArmoX® 620T	5–15 mm	0.53	0.66
ArmoX® Advance	4–12 mm	0.56–0.64	0.68–0.89

Table 1 ¹Carbon equivalents, for calculations see Equation 2 and 3. %.

The definitions of the carbon equivalents CEV and CET are given in Equation 2 and Equation 3:

$$CET = C + \frac{(Mn + Mo)}{10} + \frac{(Cr + Cu)}{20} + \frac{Ni}{40}$$

Equation 2 Carbon equivalent calculation

$$CEV = C + \frac{Mn}{6} + \frac{(Mo + Cr + V)}{5} + \frac{(Ni + Cu)}{15}$$

Equation 3 Carbon equivalent calculation

SELECTION OF WELDING CONSUMABLES

Ferritic and stainless types of consumables are recommended types of consumables. The possible types depend of the ArmoX® grade and the plate thicknesses in the joint. The following applies to all types of consumables; in order to achieve an optimum combination of strength and toughness in the welded joint, select a consumable with as low strength as possible, but which still fulfills the strength requirements for the joint. Use of low-strength consumables can offer several benefits, such as higher toughness of the weld metal, higher resistance to hydrogen cracking and lower residual stresses in the joint. Designers should therefore attempt to position the welds in low stress areas

UNALLOYED AND LOW ALLOYED FERRITIC CONSUMABLES

If unalloyed- or low alloyed ferritic consumables are selected the suitable yield strength of these consumable are below approximately 500 MPa. The recommended maximum hydrogen content of the consumables is 5 ml/100 g of weld metal. Consumables for MAG welding with solid wire and TIG welding can fulfill this demand. For other welding methods, the following types of consumables have the possibility to the maximum permitted hydrogen level:

- MAG welding with flux cored wires: Basic- and rutile types
- MAG welding with metal cored wires: Certain brand names
- SAW: Combinations of wire and basic flux

In the three last cases, exact hydrogen levels can be found in the consumable datasheet.

AUSTENITIC CONSUMABLES

The recommended austenitic consumables are according to type AWS 307 or AWS 309. We recommend, giving first preference to consumables in accordance with AWS 307 and second according to AWS 309. These types of consumables have yield strengths up to approximately 500 MPa in all the weld metal. Type AWS 307 can withstand hot cracking better than AWS 309. For stainless types of consumables no specific maximum hydrogen level is stated. The reason is the higher hydrogen solubility in austenitic consumables.

HANDLING OF CONSUMABLES

All type of consumables shall be stored according to the manufacturer's recommendations. The hydrogen content will then be maintained at the intended level. More information can be found in our TechSupport document regarding consumables. You find it under Downloads at www.ssab.com, search for "consumables".

PREHEAT TEMPERATURES

There are recommendations for both minimum and maximum preheat temperatures of the steel during welding. The minimum preheat temperatures are requested in order to avoid hydrogen cracking. Maximum preheat temperatures are on the other hand set in order to avoid degradation of the mechanical properties in the whole welded structure. Preheat recommendations are given in Table 2. The minimum preheat temperature depend of the steel grade, plate thickness in the joint, type of consumables and the heat input applied. If ferritic consumables are used, preheating is always recommended.

MINIMUM RECOMMENDED PREHEATING TEMPERATURES FOR DIFFERENT SINGLE PLATE THICKNESS (MM)

Ferretic consumables. Minimum recommended preheat for different plate thicknesses (mm).

	Thickness	3	10	20	30	40	50	60	70	80	90	100
Armox® 370T Class 1 & 2	3-100 mm	50° C	100° C	125° C	150° C	175° C	175° C	200° C	200° C	200° C	200° C	200° C
Armox® 440T	4-80 mm	50° C	75° C	125° C	150° C	175° C	175° C	200° C	200° C	200° C	200° C	200° C
Armox® 500T	3-80 mm	50° C	100° C	125° C	150° C	175° C	175° C	200° C	200° C	200° C	200° C	200° C
Armox® 520T	4-12 mm	50° C	100° C	125° C	150° C	175° C	175° C	200° C	200° C	200° C	200° C	200° C
Armox® 560T	4-15 mm	50° C	100° C	125° C	150° C	175° C	175° C	200° C	200° C	200° C	200° C	200° C

■ Only stainless steel consumables Outside the size range

Austenitic consumables. Minimum recommended preheat for different plate thicknesses (mm).

	Thickness	3	10	20	30	40	50	60	70	80	90	100
Armox® 370T Class 1 & 2	3-100 mm	Room temperature (~20° C)	Room temperature (~20° C)	Room temperature (~20° C)	Room temperature (~20° C)	Room temperature (~20° C)	Room temperature (~20° C)	Room temperature (~20° C)	100° C	100° C	100° C	100° C
Armox® 440T	4-80 mm	Room temperature (~20° C)	Room temperature (~20° C)	Room temperature (~20° C)	Room temperature (~20° C)	Room temperature (~20° C)	Room temperature (~20° C)	Room temperature (~20° C)	100° C	100° C	100° C	100° C
Armox® 500T	3-80 mm	Room temperature (~20° C)	Room temperature (~20° C)	Room temperature (~20° C)	Room temperature (~20° C)	Room temperature (~20° C)	Room temperature (~20° C)	Room temperature (~20° C)	100° C	100° C	100° C	100° C
Armox® 560T	4-15 mm	Room temperature (~20° C)	Room temperature (~20° C)	Room temperature (~20° C)	Room temperature (~20° C)	Room temperature (~20° C)	Room temperature (~20° C)	Room temperature (~20° C)	Room temperature (~20° C)	Room temperature (~20° C)	Room temperature (~20° C)	Room temperature (~20° C)
Armox® 600T	4-20 mm	Room temperature (~20° C)	Room temperature (~20° C)	Room temperature (~20° C)	Room temperature (~20° C)	Room temperature (~20° C)	Room temperature (~20° C)	Room temperature (~20° C)	Room temperature (~20° C)	Room temperature (~20° C)	Room temperature (~20° C)	Room temperature (~20° C)
Armox® 620T	5-15 mm	Room temperature (~20° C)	Room temperature (~20° C)	Room temperature (~20° C)	Room temperature (~20° C)	Room temperature (~20° C)	Room temperature (~20° C)	Room temperature (~20° C)	Room temperature (~20° C)	Room temperature (~20° C)	Room temperature (~20° C)	Room temperature (~20° C)
Armox® Advanced	4-12 mm	100° C	100° C	100° C	100° C	100° C	100° C	100° C	100° C	100° C	100° C	100° C

■ Room temperature (~20° C) Outside the size range

Table 2 The min preheat temperatures are applicable for heat inputs of 1,7kJ/mm or higher. Increase the minimum preheat temperature by 25° C in relation to the preheat table for each of the following cases:

1. Welding of firmly clamped joints.
2. For heat inputs in the range of 1.0–1.6 kJ/mm. Contact SSAB for min preheat temperatures at heat inputs below 1.0kJ/mm.
3. If the ambient humidity is high or the surrounding air- or joint temperature is below +5° C.

Room temperature refers to a temperature of the surrounding air and joint temperature of approximately 18° C–25° C. If this is not feasible temperatures down to +5° C in these areas can be accepted.

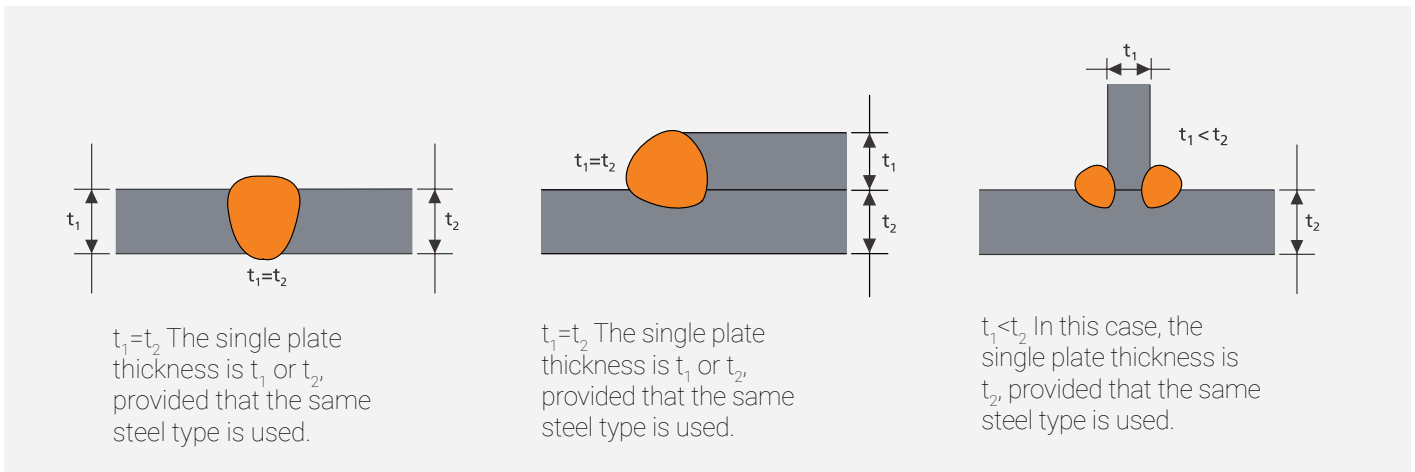

Figure 3 Single and combined plate thicknesses

Steel grade	Maximum preheat/interpass temp
Armox® 370T Class 1	400
Armox® 370T Class 2	600
Armox® 440T	190
Armox® 500T	190
Armox® 520T	170
Armox® 560T	180
Armox® 600T	160
Armox® 620T	120
Armox® Advance	120

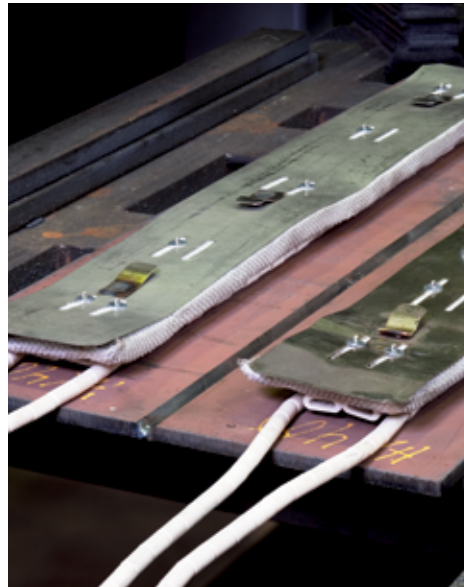

Table 3 Max preheat/interpass temperatures

Figure 4 Using preheating blankets.

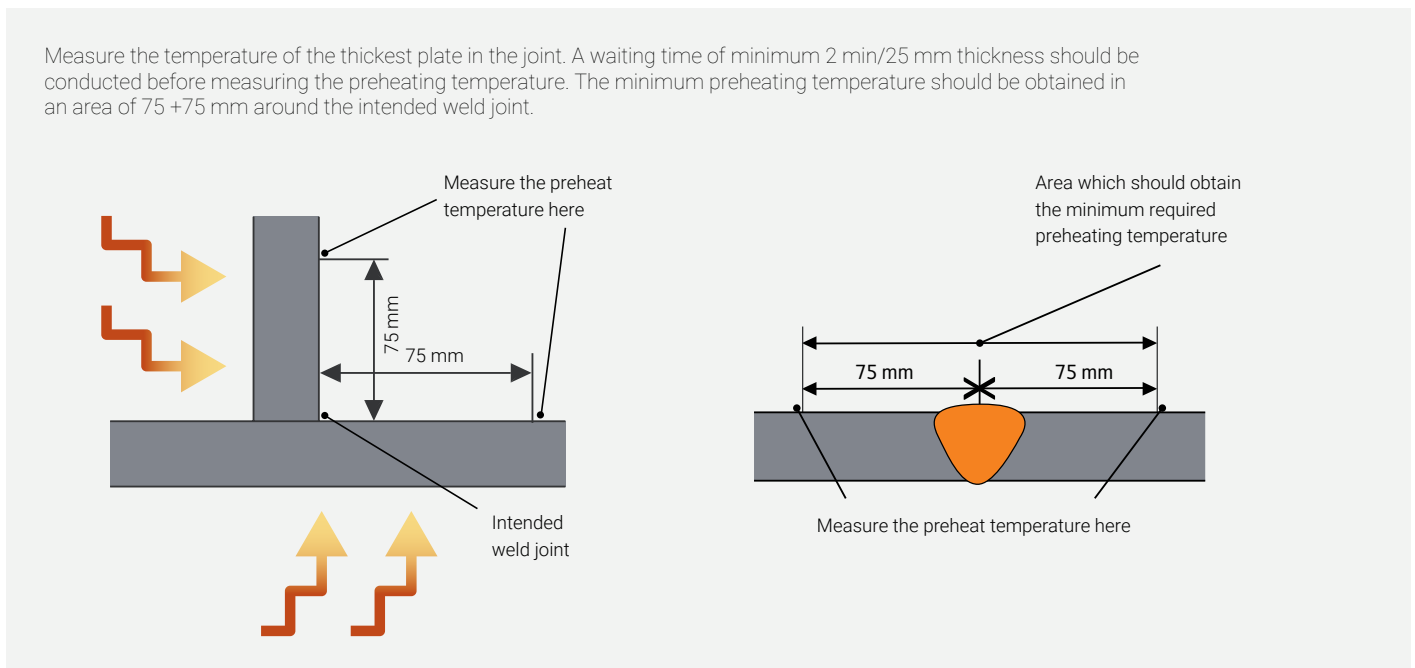

Figure 5 Performance of preheating

CUTTING RECOMMENDATIONS

All high-hardness Armox® plate (see the Table below) should be cut under controlled conditions as described below:

Armox® 370T CL 1 & 2	Armox® 440T	Armox® 500T	Armox® 520T	Armox® 560T	Armox® 600T	Armox® 620T	Armox® Advance	Recommended cutting method
Up to 15 mm	Up to 25 mm	Up to 15 mm	Up to 12 mm	Up to 15 mm	Up to 10 mm			<ul style="list-style-type: none"> • Abrasive waterjet • Plasma • Laser • Abrasive disc
15–25 mm	25–30 mm	15–25 mm			10–20 mm			<ul style="list-style-type: none"> • Abrasive waterjet • Laser • Gas cutting plus preheating to 170 ± 30° C • Abrasive disc
40–100 mm	25–30 mm	40–80 mm						<ul style="list-style-type: none"> • Abrasive waterjet • Gas cutting plus preheating to 170 ± 30° C plus keep warm for 4 hours at 160 ± 40° C • Abrasive disc
						Up to 15 mm	Up to 12 mm	<ul style="list-style-type: none"> • Abrasive waterjet • Abrasive disc • Laser

Table 4 Preferred cutting methods.

ABRASIVE WATERJET

This process can be applied to all of the Armox® plates and is the preferred method, because the absence of HAZ eliminates the risk of cracking.

LASER CUTTING

Armox® Advance and Armox® 600T up to around 20 mm thick can be cut using this process. It generates a narrow kerf, usually less than 1 mm, and a narrow HAZ, usually less than 3 mm.

PLASMA CUTTING

Armox® Advance and Armox® 600T up to around 25 mm thick can be cut using this process. It generates a kerf, usually 3–4 mm, and a HAZ up to 5 mm. Plasma cutting can be performed under water, which minimizes the amount of distortion and generates a more narrow HAZ.

GAS CUTTING

This process can be applied to Armox® plates up to 100 mm thick, see details in Table 4. It generates a kerf of 2–5 mm and a HAZ which is usually 4–10 mm wide.

Uncontrolled gas cutting of high-hardness armour plate may result in hydrogen cracking (also called cold cracking) which may occur in thicknesses above 20–30 mm. The thicker the plate, the higher the sensitivity to cracking.

The most effective technique for avoiding cracking during and after the cutting process is to preheat the plate and then keep the cut parts at an elevated temperature as can be seen in Table 4.

Preheating consists of bringing the whole plate, or at least a 100 mm wide area on either side of the future kerf, up to a specified minimum temperature before the process begins. This can be done by using thermostatically controlled furnaces, heating blankets or, in some cases, using gas burners to maintain the temperature throughout the process.

The same equipment can be used to keep the parts at keep the cut parts at an elevated temperature as can be seen in Table 4. Reduced cutting speed is possible only when the cut parts are wide enough to consume the excessive heat. If in doubt contact SSAB.

ABRASIVE DISC

This process is usually applied to the cutting of tube and rod but can also be adopted for straight line cutting of the complete range of high-hardness Armox® plate. The kerf is the thickness of the disc, with narrow or no HAZ.



Abrasive waterjet

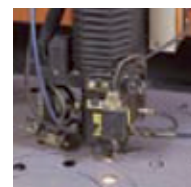

Laser cutting



Plasma cutting

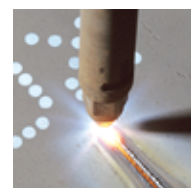

Gas cutting

MACHINING RECOMMENDATIONS

Drilling can be performed using high-speed steel drills or cemented carbide drills, when drilling in Armox® with HSS drills in radial/column drilling machines is the first choice a HSS-Co 8% drill with a small helix angle, for individual holes you can use an ordinary HSS drill.

Advice for reducing vibrations and increasing the lifetime on the drill:

- Minimize the distances to the column and between to drill tip and the workpiece.
- Don't use longer drill than necessary
- Always use metal supports
- Clamp securely
- Solid and firm table
- Use coolant
- Just before the drill breaks through, disengage the feed rate for about a second, play/spring back can otherwise snap the drill tip, Re-engage the feed rate when the play/spring back have ceased.

HSS-drill (Max drill length 3 x Diameter)

Steel grade	Cutting speed (Vc), m/min	Drill diameter, (Dc), mm			
		Feed per revolution, (fn) mm/rev			
		Ø 10 mm	Ø 15 mm	Ø 20 mm	Ø 30 mm
Armox® 370T, CL 1 & 2	7 – 10	0,10	0,16	0,23	0,35
Armox® 440T	5 – 7	0,09	0,14	0,20	0,30
Armox® 500T	3 – 5	0,08	0,12	0,16	0,24

Table 5

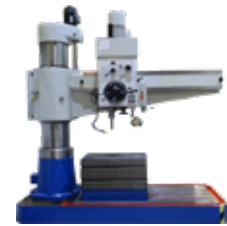

DRILLING RECOMMENDATIONS WHEN THE MACHINE CONDITIONS ARE GOOD

Solid cemented carbide drill (Max drill length 3 x Diameter)

Steel grade	Cutting speed (Vc), m/min	Drill diameter, (Dc), mm			
		Feed per revolution, (fn) mm/rev			
		Ø 3,0–5,0 mm	Ø 5,1–10,0 mm	Ø 10,01–15,0 mm	Ø 15,01–20,0 mm
Armox® 370T, CL 1 & 2	60–80	0,03–0,06	0,06–0,12	0,12–0,17	0,17–0,22
Armox® 440T	40–60	0,03–0,05	0,05–0,11	0,11–0,15	0,15–0,20
Armox® 500T	35–60	0,03–0,05	0,05–0,10	0,10–0,14	0,14–0,18
Armox® 520T	35–60	0,03–0,05	0,05–0,10	0,10–0,14	0,14–0,18
Armox® 560T	30–40	0,03–0,05	0,05–0,09	0,09–0,13	0,13–0,17
Armox® 600T	25–35	0,02–0,04	0,04–0,08	0,08–0,13	0,13–0,16
Armox® 620T	25–35	0,02–0,04	0,04–0,08	0,08–0,13	0,13–0,16
Armox® Advance	18–25	0,02–0,04	0,04–0,08	0,08–0,12	0,12–0,15

Table 6

Exchangeable-tip drill (Max drill length 3 x Diameter)



Steel grade	Cutting speed (Vc), m/min	Drill diameter, (Dc), mm			
		Feed per revolution, (fn) mm/rev			
		Ø12,0–20,0 mm	Ø 20,1–30,0 mm	Ø 30,01–44,0 mm	Ø 44,01–63,0 mm
Armox® 370T, CL 1 & 2	60–120	0,04–0,10	0,06–0,12	0,06–0,14	0,08–0,16
Armox® 440T	50–90	0,04–0,10	0,06–0,12	0,06–0,14	0,08–0,16
Armox® 500T	40–70	0,04–0,08	0,04–0,10	0,06–0,12	0,08–0,14
Armox® 520T	40–70	0,04–0,08	0,04–0,10	0,06–0,12	0,08–0,14
Armox® 560T	35–55	0,04–0,08	0,04–0,10	0,06–0,12	0,08–0,14
Armox® 600T	30–50	0,04–0,06	0,04–0,08	0,06–0,10	0,06–0,12
Armox® 620T	30–50	0,04–0,06	0,04–0,08	0,06–0,10	0,06–0,12

Table 7

Indexable Insert Drill (Max drill length 2 x Diameter)

Steel grade	Cutting speed (Vc), m/min	Drill diameter, (Dc), mm			
		Feed per revolution, (fn) mm/rev			
		Ø12,0–20,0 mm	Ø 20,01–30,0 mm	Ø 30,01–44,0 mm	Ø 44,01–63,0 mm
Armox® 370T, CL 1 & 2	60–120	0,04–0,10	0,06–0,12	0,06–0,14	0,08–0,16
Armox® 440T	50–90	0,04–0,10	0,06–0,12	0,06–0,14	0,08–0,16
Armox® 500T	40–70	0,04–0,08	0,04–0,10	0,06–0,12	0,08–0,14
Armox® 520T	40–70	0,04–0,08	0,04–0,10	0,06–0,12	0,08–0,14
Armox® 560T	35–55	0,04–0,08	0,04–0,10	0,06–0,12	0,08–0,14
Armox® 600T	30–50	0,04–0,06	0,04–0,08	0,06–0,10	0,06–0,12
Armox® 620T	30–50	0,04–0,06	0,04–0,08	0,06–0,10	0,06–0,12

Table 8

COUNTERSINKING AND COUNTERBORING

Countersinking/boring are best performed using tools which have replaceable inserts. Always use a revolving pilot and use coolant.



Counterboring/*Countersinking (Tool supplier, Granlund Tools)

Steel grade	Cutting speed (Vc), m/min	Counterbore diameter, (Dc), mm			
		Feed per revolution, (fn) mm/rev			
		Ø18,0–26,0 mm	Ø 26,00–38,0 mm	Ø 38,00–47,0 mm	Ø 47,00–60,0 mm
Armox® 370T, CL 1 & 2	20–80	0,10–0,20	0,10–0,20	0,06–0,14	0,08–0,16
Armox® 440T	20–50	0,10–0,20	0,10–0,20	0,06–0,14	0,08–0,16
Armox® 500T	15–45	0,10–0,20	0,10–0,20	0,06–0,12	0,08–0,14
Armox® 520T	15–45	0,10–0,20	0,10–0,20	0,06–0,12	0,08–0,14
Armox® 560T	10–40	0,10–0,20	0,10–0,20	0,06–0,12	0,08–0,14
Armox® 600T	10–35	0,10–0,20	0,10–0,20	0,06–0,10	0,06–0,12
Armox® 620T	10–35	0,10–0,20	0,10–0,20	0,06–0,10	0,06–0,12

Table 9

* IMPORTANT Reduce the cutting data with about 30% for countersinking.

TAPPING/THREAD MILLING

With the correct tools can all tapping/thread milling be performed in all Armox grades. We recommend four-flute taps which can withstand very high torque which occurs during tapping in hard materials. If the strength not is critical, the drilled hole can be 3% larger than standard, that will increase the lifetime on the tap.

Tapping

Steel grade	Cutting speed (Vc), m/min	Side from-to
Armox® 370T, CL 1 & 2	1-5	M6-M30
Armox® 440T	1-5	M8-M30
Armox® 500T	1-5	M10-M30



Table 10

Thread milling

Steel grade	Cutting speed (Vc), m/min	Feed per tooth, (fz) mm/tooth
Armox® 370T, CL 1 & 2	40-120	0,02-0,05
Armox® 440T	40-120	0,02-0,05
Armox® 500T	30-60	0,015-0,04
Armox® 520T	30-60	0,015-0,04
Armox® 560T	30-60	0,005-0,025
Armox® 600T	30-40	0,005-0,025
Armox® 620T	30-40	0,005-0,025
Armox® Advance	25-35	0,005-0,015

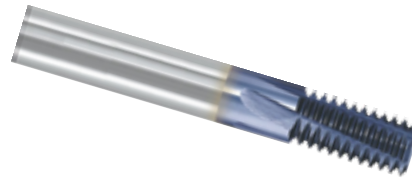

* To manage threadmilling, a CNC machine with minimum 3-axis is necessary and the thread should be made in two passes

Table 11

MILLING

To ensure rational production, milling cutters with cemented carbide inserts are recommended.

Facemilling

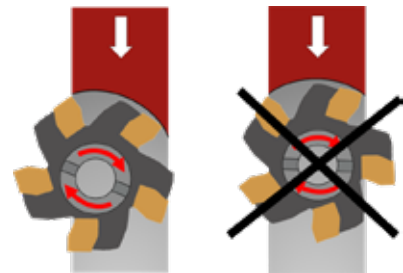

Steel grade	Cutting speed (Vc), m/min	Feed per tooth, (fz) mm/tooth	
		Min	Max
		Insert grade P20-P30	Insert grade P20-P30
Armox® 370T, CL 1 & 2	100-175	0,1	0,2
Armox® 440T	50-80	0,1	0,2
Armox® 500T	50-70	0,1	0,2
Armox® 520T	50-70	0,1	0,2
Armox® 560T	35-60	0,1	0,2
Armox® 600T	30-55	0,07	0,15
Armox® 620T	30-55	0,07	0,15
Armox® Advance	25-40	0,07	0,15

Table 12

Keep this in mind:

- Position the cutter off-centre (to the left) to achieve a thicker chip at the entry and to avoid thick chip on the exit.
- Cutter diameter should be 20-50% larger than the width of cut, ae.
- Avoid to center the cutter on centre line that will generate more vibrations.
- Always use down milling (climb milling).

BENDING RECOMMENDATIONS

This section deals with free bending, although roll bending or folding can also be employed. The bending results are dependent on a number of factors, which we have grouped under three headings: the plate, the tools and the procedure. Typical mechanical properties of the materials are given in Table 14.

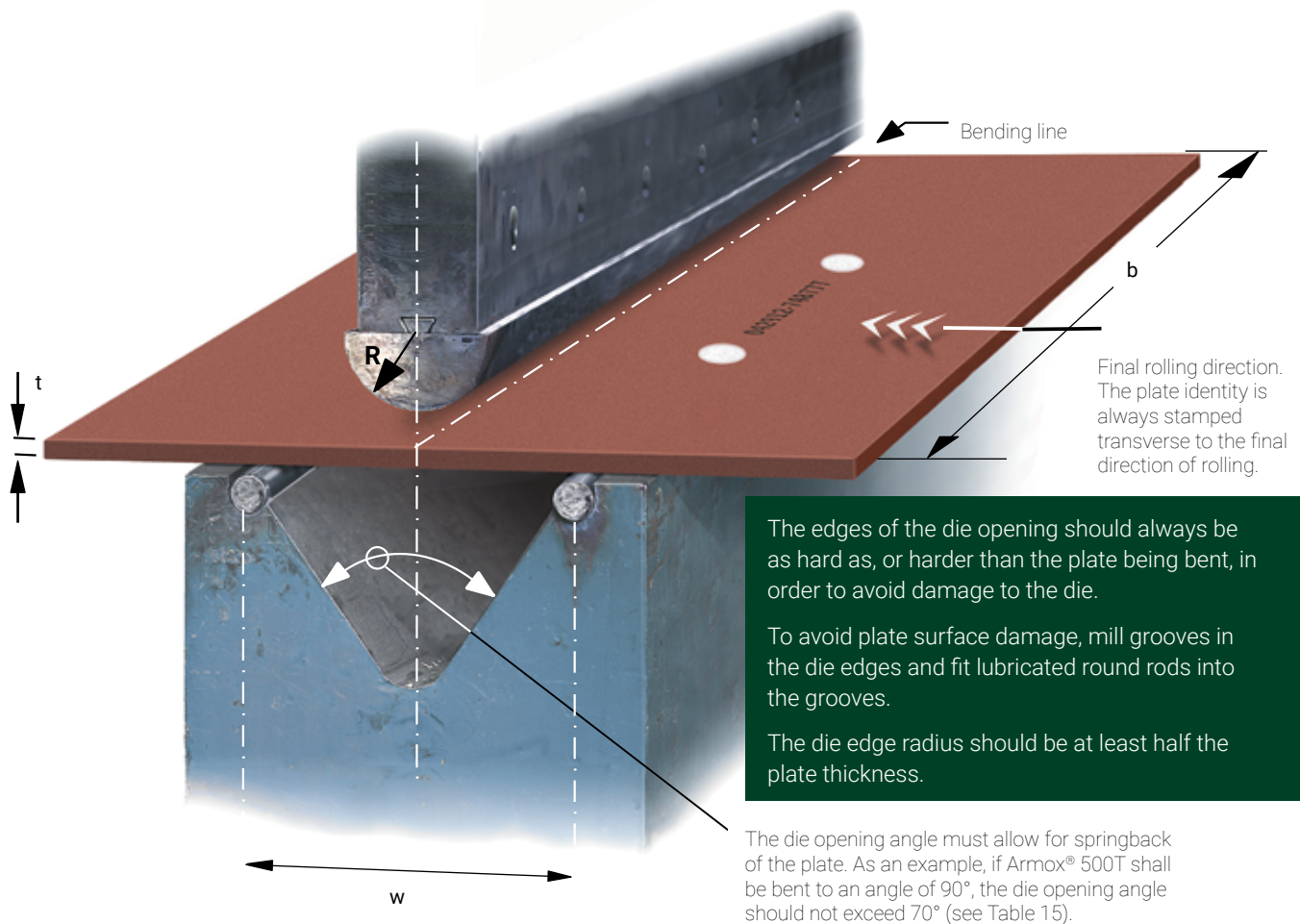

Picture 6 Minimum recommended punch radius (R) and die opening width (W) for plate thickness (t) when the plate is bent to 90° parallel to the final rolling direction and transverse to the final rolling direction – and also the corresponding springback.

Bending transverse to the final rolling direction

- Bending at right angles to the rolling direction
- Grind away any blemishes before bending
- Sheared edges should also be grounded away

The identity of the plate is always stamped across the rolling direction. Avoid placing the plate so that the stamping occurs in the bend line, due to the risk of cracking. The edges of the die opening should always be as hard as or harder than the plate being bent, in order to avoid damage to the die.

A simple way of achieving this is to mill grooves in the die edges and fit lubricated rods of hardened tool steel into the grooves. The edge radius of the die should be at least half the plate thickness. The die opening angle must allow for spring back of the plate without bottoming out in the tool. As an example, if ArmoX® 500T is to be bent to an angle of 90°, the die opening angle should not be greater than 70° (see Table 15).

The results of a bending operation are affected by the plate, the tools and the procedure employed:

THE PLATE

Steel grade

Note that the bending force and spring back increase with the plate strength. (For typical tensile strength values, see Table 14.)

Harder plates give:

- increased bending force
- increased spring back
- larger top tool radius

Plate surface

Our recommendations apply to shot blast and anti-corrosion painted plate. Surface damage and rust which is under tension during bending may greatly reduce the bendability. In critical cases, such defects can often be removed with careful grinding. Grinding scratches shall preferably be placed perpendicular to the bend line.

Plate edges

Cut and sheared edges should be deburred and rounded with a grinder.

Direction of rolling of the plate

The plate can be bent to a smaller radius at right angles to the direction of rolling than in the direction of rolling. See Figure 6 and Table 15.

Bend length (b)

If the bend length is less than 10 times the plate thickness, the plate can often be bent to a smaller radius than the values given in Table 15.

THE TOOLS

Punch radius (R)

The correct punch radius, along with the die width, is the most important parameter when bending Armox® (see Table 15). When bending high strength steel, the final inner radius often becomes somewhat smaller than the radius of the punch, see figure below. When there is low friction between plate and tools, the phenomenon becomes more obvious.

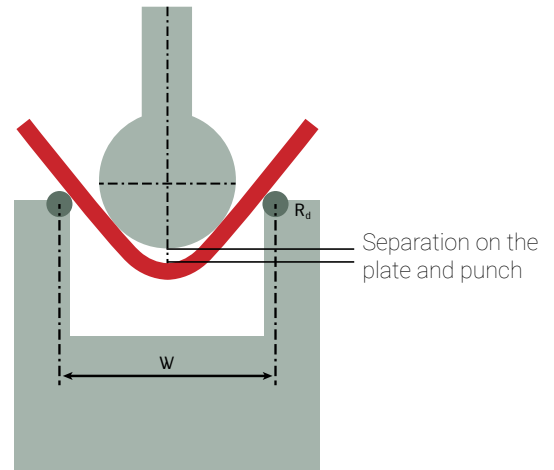

Picture 7 Separation on the plate during bending.

	Thickness [mm]	Transverse R/t	Parallel R/t	Recommended W/t
Armox® 370T Class 1	< 8	3.0	3.5	10
	8–14.9	4.0	4.0	10
	≥ 15	5.0	5.5	10
Armox® 370T Class 2	< 15	2.5	2.5	10
	< 15	2.5	3.0	10
Armox® 440T	< 15	4.0	4.0	12
	≥ 15	4.5	4.5	14
Armox® 500T	< 15	4.0	4.0	14
	≥ 15	5.5	5.5	16
Armox® 520T	< 12	4.0	4.0	14
Armox® 560T	≤ 15	4.5	4.5	14
Armox® 600T	< 15	5.0	5.0	4.0
	≥ 15	6.0	6.0	5.5
Armox® 620T	Contact SSAB			
Armox® Advance	Contact SSAB			

Table 15 The minimum recommended punch radius (R) and die opening width (W) for plate thickness (t) when the plate is being bent to 90° parallel or perpendicular to the final rolling direction.

Care should be taken during all bending – due to the high strength of the plate and the high bending force necessary. If the plate should crack, fragments of the material may fly off. During bending, the operator and other personnel must therefore not stand in front of the equipment – they should move to the side.

THE TOOLS (CONT'D)

Die opening width (W)

Table 15 specifies the minimum recommended die opening. If the width is increased, the bending force and indentation marks will admittedly be reduced, but at the expense of increased spring back.

Note that the opening angle must be small enough to allow a sufficient amount of over-bending (see Picture 7 and Table 15). In roll bending, the spring back will be much larger.

BENDING PROCEDURE

Friction

The die edges must be clean and undamaged. The bending force needed and the risk of cracking can be reduced by using round rods free to rotate as die edges and/or by lubricating the die edges.

Bending angle

The recommendations in Table 15 relates to bending to an angle of 90 degrees. Note that the bending angle has a lesser effect on the force needed and the spring back than the die opening width and steel grade. Spring back can be compensated by over-bending.

Bending force (P)

To make an estimation of the force needed during bending, we pay attention not only to the bend length, plate thickness, die width and tensile strength, but also the changing moment arm during bending. The peak load is assumed to be reached at a bend opening angle of 120° with normal friction (no lubrication). Trial tests are always recommended.

$$P = \frac{b \cdot t^2 \cdot R_m}{(W - R_d - R_p) \cdot 9\,800}$$

P = Bend force, tons (metric)	R _m = Tensile strength, MPa (Table 14)
t = Plate thickness, mm	R _d = Die entry radius, mm
W = Die width, mm (figure 1)	R _p = Punch radius, mm
b = Bend length, mm	

Picture 8

DIE WIDTH

Spring back increases with increased die width, while punch force is reduced. Make sure that the opening angle of the die allows for over-bending without bottoming out, to compensate for spring back. An increased die opening width can in many cases lower the strain level in the bend. Also, make sure that there is enough room for the chosen punch together with the workpiece, in the die, during bending, without deforming the die. The minimum recommended die opening width are shown in Table 15.

The die should preferably be equipped with round lubricated rods of hardened tool steel as mentioned earlier. If the die doesn't have rollers, the die edge radius should be at least half of the plate thickness. Alternatively, the die width should be increased in order to minimize pressure on the die edge radius, and consequently reduce the risk of die marks. To avoid excessive tool wear, tooling should be harder than the workpiece.

SSAB is a Nordic and US-based steel company. SSAB offers value added products and services developed in close cooperation with its customers to create a stronger, lighter and more sustainable world. SSAB has employees in over 50 countries. SSAB has production facilities in Sweden, Finland and the US. SSAB is listed on the Nasdaq OMX Nordic Exchange in Stockholm and has a secondary listing on the Nasdaq OMX in Helsinki.

SSAB
SE-613 80 Oxelösund
Sweden

T +46 155 25 40 00
F +46 155 25 40 73
contact@ssab.com

www.ssab.com

SSAB

This leaflet contains general suggestions and calculation models. SSAB Oxelösund AB does hereby expressly exclude any liability whatsoever for their suitability for individual applications. It is the responsibility of the user of the manual to adapt the recommendations contained herein to the requirements of individual applications.
701-en-Armox-Workshop-recommendations-V3-2024-Solbodesign-Österbergs tryckeri.